

Features



- Allows PC users to perform the following functions:
 - Program MAX® 9000, MAX 7000S, MAX 7000A, MAX 7000B, and MAX 3000A devices in-system via a standard parallel port
 - Configure Stratix™, APEX™ II, APEX 20K (including APEX 20K, APEX 20KE, and APEX 20KC), ACEX® 1K, Mercury™, FLEX® 10K (including FLEX 10KA and FLEX 10KE), FLEX 8000, and FLEX 6000 devices and Excalibur™ embedded processor solutions
- Supports operation while powered up with V_{CC} at 3.3 V or 5.0 V
- Provides a fast and low-cost method for in-system programming
- Downloads data from the MAX+PLUS® II or Altera® Quartus® II development software
- Interfaces with a standard 25-pin parallel port on PCs
- Uses a 10-pin circuit board connector, which is identical to the ByteBlaster™ parallel port and BitBlaster™ serial download cables
- Supports SignalTap® II logic analysis in the Quartus II software

Functional Description

The ByteBlasterMV parallel port download cable (ordering code: PL-BYTEBLASTERMV) interfaces to a standard PC parallel port (also known as an LPT port). This cable drives configuration data from the PC to Stratix, APEX II, APEX 20K (including APEX 20K, APEX 20KE, and APEX 20 KC), ACEX 1K, Mercury, Excalibur, FLEX 10K (including FLEX 10KA and FLEX 10KE), FLEX 8000, and FLEX 6000 devices, as well as programming data to MAX 9000, MAX 7000S, MAX 7000A, MAX 7000B, MAX 3000A devices and configuration devices. Because design changes are downloaded directly to the device, prototyping is easy and multiple design iterations can be accomplished in quick succession. See Figure 1.

Figure 1. ByteBlasterMV Parallel Port Download Cable

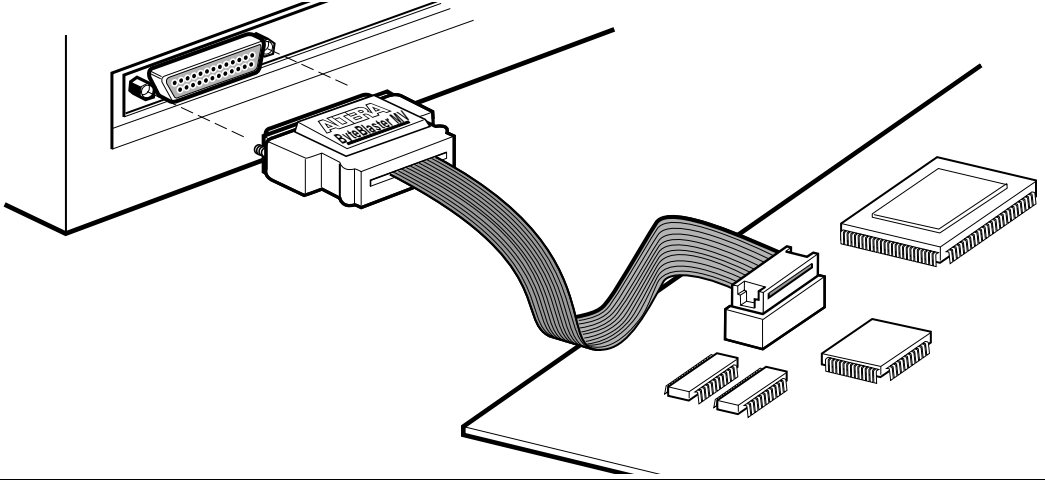

Download Modes

The ByteBlasterMV cable provides two download modes:

- Passive serial (PS) mode—Used for configuring APEX II, APEX 20K, Mercury, ACEX 1K, Excalibur, FLEX 10K, FLEX 8000, and FLEX 6000 devices
- JTAG mode—Industry-standard Joint Test Action Group (JTAG) interface for programming or configuring APEX II, APEX 20K, Mercury, ACEX 1K, Excalibur, FLEX 10K, MAX 9000, MAX 7000S, MAX 7000A, MAX 7000B, and MAX 3000A devices

ByteBlasterMV Connections

The ByteBlasterMV cable has a 25-pin male header that connects to the PC parallel port, and a 10-pin female plug that connects to the circuit board. Data is downloaded from the PC's parallel port through the ByteBlasterMV cable to the circuit board via the connections discussed in this section.



To configure 1.5-V APEX II, 1.8-V APEX 20KE, 2.5-V APEX 20K, and Excalibur, Mercury, ACEX 1K, and FLEX 10KE devices using the ByteBlasterMV download cable, connect the pull-up resistors to a 3.3-V power supply, and the cable's VCC pin to a 3.3-V power supply, and the device's VCCINT pin to an appropriate 2.5-V, 1.0-V, or 1.5-V power supply. For PS configuration, the device's VCCIO pin must be connected to a 2.5-V or 3.3-V power supply. The ByteBlasterMV VCC pin must be connected to 3.3 V for APEX II, Mercury, ACEX 1K, APEX 20K, and FLEX 10KE JTAG configuration, or MAX 7000A and MAX 3000A JTAG in-system programming. The device VCCIO pin can be connected to either a 2.5-V or 3.3-V power supply. The ByteBlasterMV VCC pin must be connected to a 3.3- or 5.0-V power supply for MAX 7000S in-system programming and must be connected to a 5.0-V power supply for MAX 9000 in-system programming.

ByteBlasterMV Header & Plug Connections

The 25-pin male header connects to a parallel port with a standard parallel cable. Table 1 identifies the pins and the download modes.

Pin	PS Mode Signal Name	JTAG Mode Signal Name
2	DCLK	TCK
3	nCONFIG	TMS
8	DATA0	TDI
11	CONF_DONE	TDO
13	nSTATUS	–
15	VCC	VCC
18 to 25	GND	GND

Figure 2 shows a schematic of the ByteBlasterMV download cable.

Figure 2. ByteBlasterMV Schematic

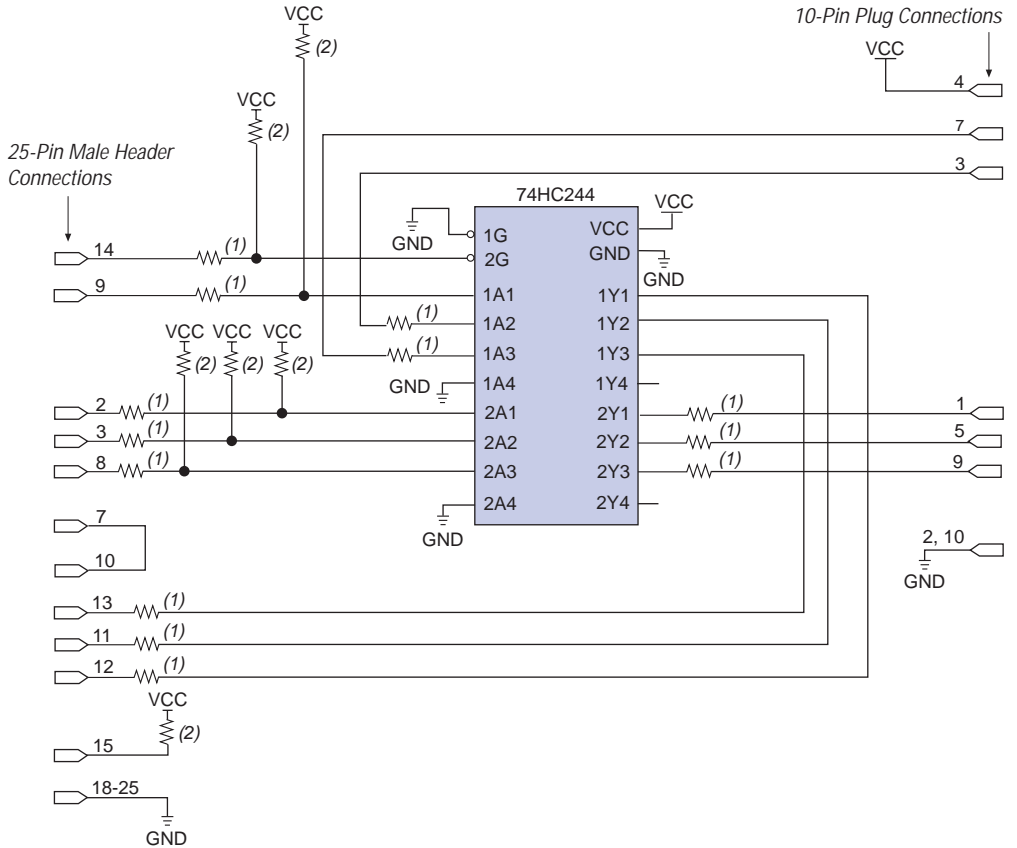

Notes:

- (1) All series resistors are 100 Ω.
- (2) All pull-up resistors are 2.2 kΩ.

The 10-pin female plug connects to a 10-pin male header on the circuit board containing the target device(s). Figure 3 shows the dimensions of the female plug.

Figure 3. ByteBlasterMV 10-Pin Female Plug Dimensions

Dimensions are shown in inches. The spacing between pin centers is 0.1 inch.

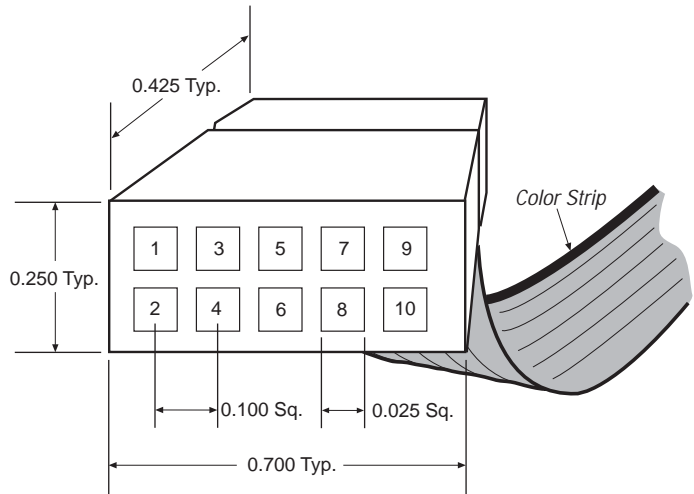



Table 2 identifies the 10-pin female plug's pin names for the corresponding download mode.

Pin	PS Mode		JTAG Mode	
	Signal Name	Description	Signal Name	Description
1	DCLK	Clock signal	TCK	Clock signal
2	GND	Signal ground	GND	Signal ground
3	CONF_DONE	Configuration control	TDO	Data from device
4	VCC	Power supply	VCC	Power supply
5	nCONFIG	Configuration control	TMS	JTAG state machine control
6	–	No connect	–	No connect
7	nSTATUS	Configuration status	–	No connect
8	–	No connect	–	No connect
9	DATA0	Data to device	TDI	Data to device
10	GND	Signal ground	GND	Signal ground

 The circuit board must supply V_{CC} and ground to the ByteBlasterMV cable.

Circuit Board Header Connection

The ByteBlasterMV 10-pin female plug connects to a 10-pin male header on the circuit board. The 10-pin male header has two rows of five pins, which are connected to the device’s programming or configuration pins. The ByteBlasterMV cable receives power and downloads data via the male header. Figure 4 shows the dimensions of a typical 10-pin male header.

Figure 4. 10-Pin Male Header Dimensions

Dimensions are shown in inches.

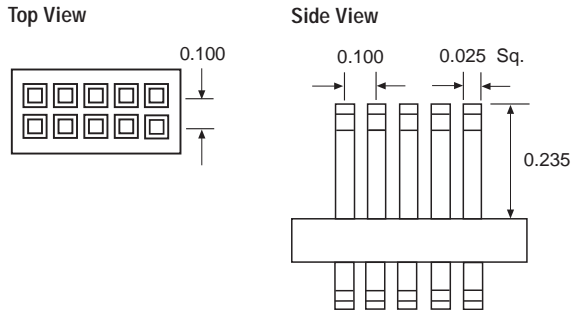

Operating Conditions

Tables 3 through 5 summarize the absolute maximum ratings, recommended operating conditions, and DC operating conditions for the ByteBlasterMV cable.

Table 3. ByteBlasterMV Cable Absolute Maximum Ratings

Symbol	Parameter	Conditions	Min	Max	Unit
V_{CC}	Supply voltage	With respect to ground	-0.5	7.0	V
V_I	DC input voltage	With respect to ground	-0.5	7.0	V

Table 4. ByteBlasterMV Cable Recommended Operating Conditions

Symbol	Parameter	Conditions	Min	Max	Unit
V_{CC}	Supply voltage, 5.0-V operation		4.5	5.5	V
	Supply voltage, 3.3-V operation		3.0	3.6	V

Table 5. ByteBlasterMV Cable DC Operating Conditions

Symbol	Parameter	Conditions	Min	Max	Unit
V _{IH}	High-level input voltage	V _{CC} = 4.5 V	3.15		V
		V _{CC} = 3.0 V	2.1		V
V _{IL}	Low-level input voltage	V _{CC} = 4.5 V		1.35	V
		V _{CC} = 3.0 V		0.9	
V _{OH}	5.0-V high-level TTL output voltage	TTL load. V _{CC} = 4.5 V, I _{OH} = 8 mA	3.80		V
	3.3-V high-level TTL output voltage	TTL load. V _{CC} = 3.0 V, I _{OH} = 4 mA	2.48		V
	5.0-V high-level CMOS output voltage	CMOS load. V _{CC} = 4.5 V, I _{OH} = 50 μA	4.4		V
	3.3-V high-level CMOS output voltage	CMOS load. V _{CC} = 3.0 V, I _{OH} = 50 μA	2.9		V
V _{OL}	5.0-V low-level TTL output voltage	TTL load. V _{CC} = 4.5 V, I _{OL} = 8 mA		0.44	V
	3.3-V low-level TTL output voltage	TTL load. V _{CC} = 3.0 V, I _{OL} = 4 mA		0.44	V
	5.0-V low-level CMOS output voltage	CMOS load. V _{CC} = 4.5 V, I _{OL} = 50 μA		0.1	V
	3.3-V low-level CMOS output voltage	CMOS load. V _{CC} = 3.0 V, I _{OL} = 50 μA		0.1	V
I _{CC}	Operating current			50	mA

Software Instructions

Altera's Quartus II and the MAX+PLUS II design software packages provide the programmer function required to configure or program devices using the ByteBlasterMV download cable.

Quartus II Instructions

To configure or program one or more devices with the ByteBlasterMV cable and the Quartus II programmer

1. Compile a project. The Quartus II compiler generates a **.sof** file to configure APEX II, APEX 20K, Mercury, and Excalibur devices. To program an EPC configuration device, a **.pof** or JAM STAPL format file should be used.
2. Attach the ByteBlasterMV cable to a parallel port on a PC and insert the 10-pin female plug into the prototype system containing the target device. The board must supply power to the ByteBlasterMV cable.



For the Windows NT operating system, a driver must be installed before using the ByteBlasterMV cable. For instructions on installing ByteBlasterMV drivers, go to the “ByteBlaster MV and MasterBlaster Installation” section in the *Quartus II Installation and Licensing for PCs Manual*. If you do not see a selection for the ByteBlasterMV cable in the hardware setup windows, the ByteBlasterMV driver is not installed.

3. Open the Quartus II programmer by selecting **Open Programmer** from the (Processing menu). Choose **Setup...** in the Programming Hardware section. Specify the ByteBlasterMV cable and the appropriate LPT port. Please see “Changing Setup” under the ByteBlasterMV cable in the Quartus II software Help menu for more information.
4. Select either passive serial or JTAG programming mode and then add the files and/or devices you want to program or configure using the **add file...** or **add device...** buttons to create a chain description file (.cdf).



The programmer has two programming modes: passive serial and JTAG. In passive serial mode, you select which SOFs to include in the device chain. In JTAG mode, you add specific devices and configuration devices to the device chain, in addition to POFs and SOFs, and you have several programming options for each configuration device in the chain. In JTAG mode, you can verify an EPC configuration device’s contents against its programming file data, check that a device is blank, examine a programmed device and save its data to file, or use its data to program or verify another configuration device.

5. Choose the **start** button in the Quartus II software to program or configure the device(s). The ByteBlasterMV cable downloads the data from the SOF and/or POF file(s) into the device(s).



For more instructions, please refer to Quartus II Help.

MAX+PLUS II Instructions

To configure or program one or more devices with the ByteBlasterMV cable and the MAX+PLUS II programmer:

1. Compile a project. The compiler automatically generates an SRAM Object File (.sof) for FLEX 10K, FLEX 8000, and FLEX 6000 device configuration, or a Programmer Object File (.pof) for MAX 9000, MAX 7000S, MAX 7000A, MAX 7000B, and MAX 3000A device programming.

2. Attach the ByteBlasterMV cable to a parallel port on a PC and insert the 10-pin female plug into the prototype system containing the target device. The board must supply power to the ByteBlasterMV cable.



For the Windows NT operating system, a driver must be installed before using the ByteBlasterMV cable. Go to the *MAX+PLUS II Getting Started Manual* for instructions on installing ByteBlasterMV drivers. If you do not see a selection for the ByteBlasterMV cable in the hardware setup windows, the ByteBlasterMV driver is not installed.

3. Open the MAX+PLUS II programmer. Choose the **Hardware Setup** command (Options menu) to specify the ByteBlasterMV cable and the appropriate LPT port. See “Changing the Hardware Setup” in MAX+PLUS II Help for more information.
4. The MAX+PLUS II software automatically loads the programming file for the current project (either a POF or SOF), or the first programming file for a multi-device project. To specify another programming file, choose **Select Programming File** (File menu) and specify the correct file. For a FLEX 10K, FLEX 8000, or FLEX 6000 device, select an SOF; for a MAX 9000, MAX 7000S, MAX 7000A, or MAX 3000A device, select a POF.
5. For JTAG or FLEX-chain programming or configuration, perform the following steps: To program or configure devices in a JTAG chain (multi- or single-device chain), turn on **Multi-Device JTAG-Chain** (JTAG menu) and choose **Multi-Device JTAG Chain Setup** to set up the multi-device JTAG chain. See “Setting up Multi-Device JTAG Chains” in MAX+PLUS II Help for more information.
6. If the JTAG chain includes either FLEX or MAX devices exclusively, set up and create just one JTAG Chain File (.jcf). Likewise, if the JTAG chain includes a mixture of FLEX and MAX devices, set up and create two separate JCFs. One JCF will configure the FLEX devices, and the other JCF will program the MAX devices.
7. To configure multiple devices in a FLEX chain, turn on **Multi-Device FLEX Chain** (FLEX menu) and choose **Multi-Device FLEX Chain Setup** to set up the multi-device FLEX chain. See “Setting Up Multi-Device FLEX Chains” in MAX+PLUS II Help for more information.
8. Choose the **Program** or **Configure** buttons in the MAX+PLUS II software to program or configure the device(s). The ByteBlasterMV cable downloads the data from the SOF or POF File(s) into the device(s).



For more instructions, please refer to MAX+PLUS II Help.

Conclusion

Downloading configuration and programming data directly to the device via the ByteBlasterMV cable allows designers to verify multiple design iterations in quick succession, thereby speeding the design cycle.

References

For more information on configuration and in-system programmability (ISP), see the following sources:

- *Application Note 116 (Configuring APEX 20K, FLEX 10K & FLEX 6000 Devices)*
- *Application Note 33 (Configuring FLEX 8000 Devices)*
- *Application Note 38 (Configuring Multiple FLEX 8000 Devices)*
- *Application Note 39 (IEEE 1149.1 (JTAG) Boundary-Scan Testing in Altera Devices)*
- *Application Note 95 (In-System Programmability in MAX Devices)*
- Search for “Configuring a Single Device with the BitBlaster, ByteBlaster, or FLEX Download Cable”, “Setting Up Multiple-Device JTAG chains”, “Configuring Multiple Devices in a JTAG Chain with the BitBlaster or ByteBlaster”, and “Programming Multiple Devices in a JTAG Chain with the BitBlaster or ByteBlaster” in MAX+PLUS II Help.
- Search for “ByteBlasterMV”, “Programming a Single Device or Multiple Devices in JTAG or Passive Serial Chains with the MasterBlaster or ByteBlasterMV”, “Configuration Scheme Description”, “Programmer Introduction”, and “Programming” in Quartus II Help.

Revision History

The information contained in the *ByteBlasterMV Parallel Port Download Cable Data Sheet* version 3.3 supersedes information published in previous versions.

The *ByteBlasterMV Parallel Port Download Cable Data Sheet* version 3.3 contains the following change:

- Text addition to the list at the top of page 1.



101 Innovation Drive
San Jose, CA 95134
(408) 544-7000
<http://www.altera.com>
Applications Hotline:
(800) 800-EPLD
Literature Services:
lit_req@altera.com

Copyright © 2002 Altera Corporation. All rights reserved. Altera, The Programmable Solutions Company, the stylized Altera logo, specific device designations, and all other words and logos that are identified as trademarks and/or service marks are, unless noted otherwise, the trademarks and service marks of Altera Corporation in the U.S. and other countries. All other product or service names are the property of their respective holders. ARM is a registered trademark of ARM Limited. ModelSim and Mentor Graphics are registered trademarks and LeonardoSpectrum, Exemplar Logic, and Model Technology are trademarks of Mentor Graphics Corporation. Altera products are protected under numerous U.S. and foreign patents and pending applications, maskwork rights, and copyrights. Altera warrants performance of its semiconductor products to current specifications in accordance with Altera's standard warranty, but reserves the right to make changes to any products and services at any time without notice. Altera assumes no responsibility or liability arising out of the application or use of any information, product, or service described herein except as expressly agreed to in writing by Altera Corporation. Altera customers are advised to obtain the latest version of device specifications before relying on any published information and before placing orders for products or services.

