

8-bit LCD Interface Notes (Crystalfontz LCD)

LCD Panel Pinouts and Connections to CPU (for data bus connectivity)

- Verify that the position of pin 1 on your LCD board. There should be a 1 next to pin 1 and a 16 next to pin 10. Our LCD panel is arranged as shown to the right (as viewed from the display side of the LCD). Note that to read the text on the LCD properly, the pins should be on the top, as shown in the figure.
- The register select signal (RS) determines whether the Data Bit values are interpreted as a command or data (aka: a character to display).
- The enable pin (E) functions as the command/data latching signal for the LCD. The LCD will latch in whatever is on the Data Bits and process it on the falling edge of the E signal.
- We are using the LCD in Read and Write mode. If you want to read from the device, DB7 is the busy flag (BF) that when clear means the LCD is ready for the next command. If this is done the delays in the below flow chart are unnecessary.

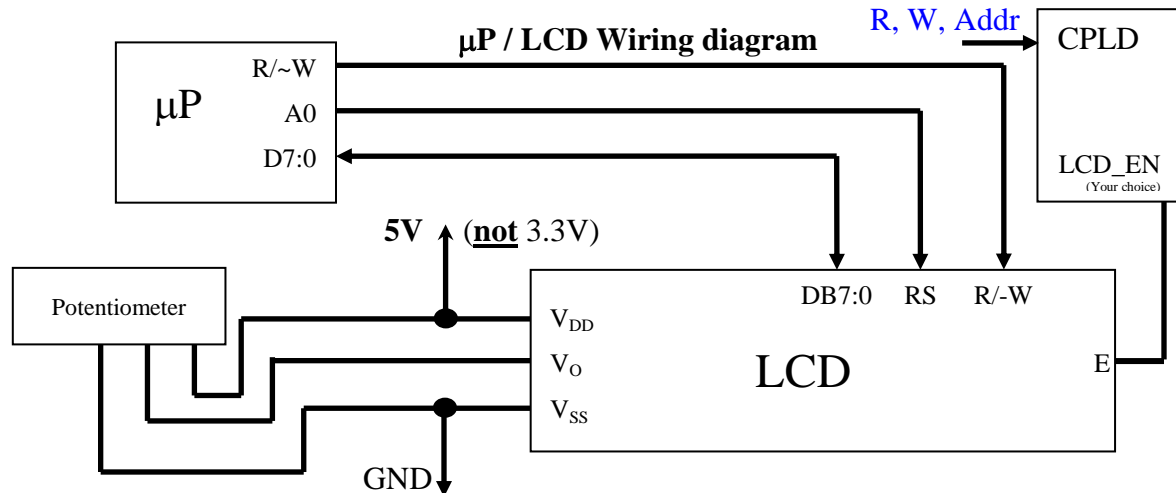
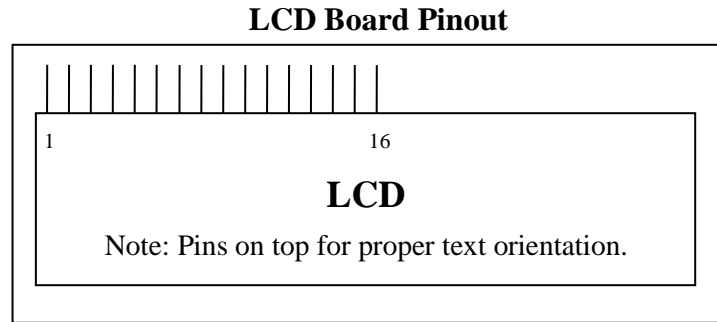

- You can verify that your LCD works properly before connecting your LCD data pins. Give power to the device and twist the potentiometer one way or the other until you see black lines appear.
- Data or commands are read at the **falling edge of E**, as shown in the timing diagram below

The Densitron LM2022 LCD specifications (posted on our website) are shown below. Our Crystalfontz LCD specifications are similar, and also posted on our website. The timing diagrams (see below) are the same.

Parameter (in ns)	Symbol	Min	Max
Enable Cycle Time	T_{CYC}	500	—
Enable Pulse Width	PW_{EH}	230	—
Enable Rise/Fall Time	t_{Er} / t_{Ef}	—	20
Address Setup Time	t_{AS}	40	—
Address Hold Time	t_{AH}	10	—
Write Data Setup Time	t_{DSW}	80	—
Write Data Hold Time	t_{DHW}	10	—

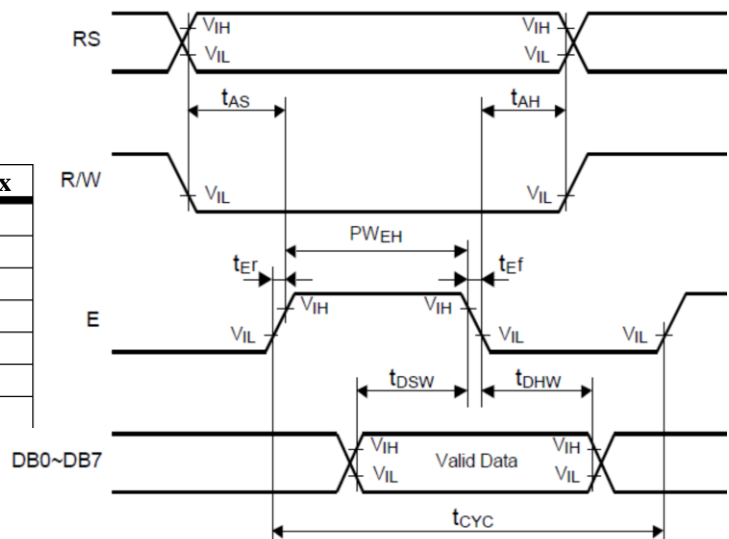

8-bit LCD Interface Notes (Crystalfontz LCD)

LCD Pin assignments			
Adapted from the Crystalfontz CFAH1602ZZ LCD SpecSheet			
Pin #	Symbol	I/O	Function
1	V _{SS}	-	Ground (0V)
2	V _{DD}	-	Logic Supply Voltage (+5V)
3	V _O	-	LCD Drive voltage for contrast adjustment
4	RS	I	Register Select 0: Command Register 1: Data Register
5	R/W	I	Read/Write 0: Data Write (Module ← MPU) 1: Data Read (Module → MPU) <i>(Connect to GROUND if only writing to LCD)</i>
6	E	I	Enable Signal Active High
7	DB0	I/O	Bi-directional data bus line 0 (LSB)
8	DB1	I/O	Bi-directional data bus line 1
9	DB2	I/O	Bi-directional data bus line 2
10	DB3	I/O	Bi-directional data bus line 3
11	DB4	I/O	Bi-directional data bus line 4
12	DB5	I/O	Bi-directional data bus line 5
13	DB6	I/O	Bi-directional data bus line 6
14	DB7 (BF)	I/O	Bi-directional data bus line 7 (MSB)
15	A (LED +)	-	Optional: LED Backlight Anode
16	A (LED -)	-	Optional: LED Backlight Cathode

Contrast and Optional Backlight Information

The optimal contrast for the LCD (V_O) is 3.3 - 3.7V, but this may vary with viewing angle, ambient temperature and per-LCD.

Setting the backlight up is optional, but may increase the readability of the LCD and is pretty cool. The backlight on your LCD is one large green LED. From the Crystalfontz documentation, the backlight requires a current-limiting resistor in the configuration shown to the right. The formula for calculating this value is shown below. LED Forward Voltage and Forward Current are 4.1V and .12A, respectively, from the Crystalfontz documentation.

$$R_{limit_{min}} = \frac{V_{DD} - V_{LED}}{I_{LED}}$$

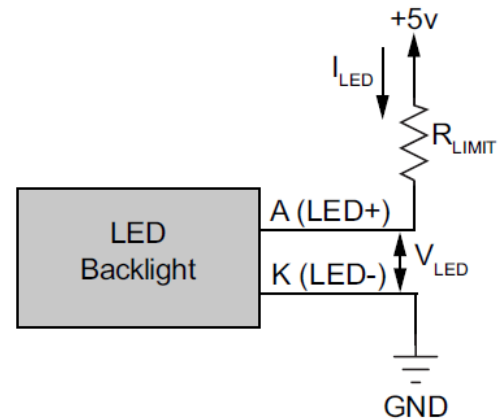

Initialization

The module powers up in 8-bit mode. Additional commands are required to put the module into 4-bit mode; however, we are going to continue using it in 8-bit mode. The suggested initialization sequence is shown below under Normal Further Initialization.

Normal Further Initialization

<Wait 40us or till BF=0>

(Two lines) [DB=\$38]

RS	R/W	DB7	DB6	DB5	DB4	DB3	DB2	DB1	DB0
0	0	0	0	1	1	1	0	0	0

<Wait 40us or till BF=0>

8-bit LCD Interface Notes (Crystalfontz LCD)

(Display on; cursor on; blink on) [DB=\$0F]

RS	R/W	DB7	DB6	DB5	DB4	DB3	DB2	DB1	DB0
0	0	0	0	0	0	1	1	1	1

<Wait 40us or till BF=0>

(Clear screen; cursor home) [DB=\$01]

RS	R/W	DB7	DB6	DB5	DB4	DB3	DB2	DB1	DB0
0	0	0	0	0	0	0	0	0	1

<Wait 1.64ms or till BF=0>

<INITIALIZATION COMPLETE>

Other useful Commands

***(Increment cursor to the right when writing; don't shift screen) [DB=\$06]**

RS	R/W	DB7	DB6	DB5	DB4
0	0	0	0	0	0
0	0	0	1	1	0

<Wait 40us or till BF=0>

(Display off; cursor off; blink off) [DB=\$08]

RS	R/W	DB7	DB6	DB5	DB4
0	0	0	0	0	0
0	0	1	0	0	0

<Wait 40us or till BF=0>

LCD Initialization

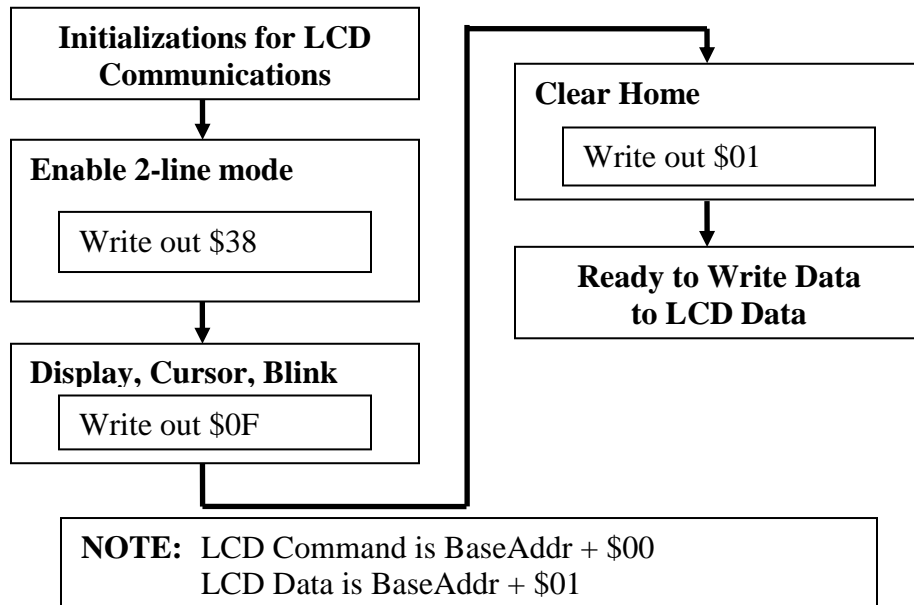

8-bit LCD Interface Notes (Crystalfontz LCD)

MORE LCD COMMANDS

Command	Code	Delay
Clear Display, Cursor to Home	\$01	1.65ms
Cursor to Home	\$02	1.65ms
Entry Mode:		
Cursor Decrement, Shift off	\$04	40μs
Cursor Decrement, Shift on	\$05	40μs
Cursor Increment, Shift off	\$06	40μs
Cursor Increment, Shift on	\$07	40μs
Display Control:		
Display, Cursor, and Cursor Blink off	\$08	40μs
Display on, Cursor and Cursor Blink off	\$0C	40μs
Display and Cursor on, Cursor Blink off	\$0E	40μs
Display, Cursor, and Cursor Blink on	\$0F	40μs
Cursor / Display Shift: (nondestructive move)		
Cursor shift left	\$10	40μs
Cursor shift right	\$14	40μs
Display shift left	\$18	40μs
Display shift right	\$1C	40μs
Display Function (2 rows for 4-bit data; big)	\$2C	40μs
Display Function (2 rows for 4-bit data; small))	\$28	40μs
Display Function (1 row for 4-bit data; big)	\$24	40μs
Display Function (1 row for 4-bit data; small)	\$20	40μs
Display Function (2 rows for 8-bit data; big)	\$3C	40μs
Display Function (2 rows for 8-bit data; small)	\$38	40μs
Display Function (1 row for 8-bit data; big)	\$34	40μs
Display Function (1 row for 8-bit data; small)	\$30	40μs
Move cursor to beginning of second row	\$C0	40μs
Character Generator RAM Address set	\$40-\$7F	40μs
Display RAM Address set	\$80-\$FF	40μs

8-bit LCD Interface Notes (Crystalfontz LCD)

LCD Character Codes

Higher Lower 4bit 4bit	0000	0010	0011	0100	0101	0110	0111	1010	1011	1100	1101	1110	1111
xxxx0000		0	a	P	`	f		-	9	E	o	p	
xxxx0001		!	1	A	Q	a	q	.	7	7	G	ä	q
xxxx0010		"	2	B	R	b	r	ˆ	ı	ı	ı	ı	ı
xxxx0011		#	3	C	S	c	s	ˆ	ı	ı	ı	ı	ı
xxxx0100		\$	4	D	T	d	t	ˆ	ı	ı	ı	ı	ı
xxxx0101		%	5	E	U	e	u	ˆ	ı	ı	ı	ı	ı
xxxx0110		&	6	F	V	f	v	ˆ	ı	ı	ı	ı	ı
xxxx0111		'	7	G	W	g	w	ˆ	ı	ı	ı	ı	ı
xxxx1000		(8	H	X	h	x	ˆ	ı	ı	ı	ı	ı
xxxx1001)	9	I	Y	i	y	ˆ	ı	ı	ı	ı	ı
xxxx1010		*	:	J	Z	j	z	ˆ	ı	ı	ı	ı	ı
xxxx1011		+	:	K	K	k	k	ˆ	ı	ı	ı	ı	ı
xxxx1100		,	<	L	#	l	l	ˆ	ı	ı	ı	ı	ı
xxxx1101		=	=	M	I	m	i	ˆ	ı	ı	ı	ı	ı
xxxx1110		.	>	N	^	n	n	ˆ	ı	ı	ı	ı	ı
xxxx1111		/	?	O	_	o	o	ˆ	ı	ı	ı	ı	ı

8-bit LCD Interface Notes (Crystalfontz LCD)

SUMMARY OF LCD COMMANDS

Instruction	Code										Description	
	RS	R/W	DB7	DB6	DB5	DB4	DB3	DB2	DB1	DB0		
Clear display	0	0	0	0	0	0	0	0	0	1	Clears display and returns cursor to the home position (address 0).	
Cursor home	0	0	0	0	0	0	0	0	0	1	*	Returns cursor to home position (address 0). Also returns display being shifted to the original position. DDRAM contents remains unchanged.
Entry mode set	0	0	0	0	0	0	0	0	1	I/D	S	Sets cursor move direction (I/D), specifies to shift the display (S). These operations are performed during data read/write.
Display On/Off control	0	0	0	0	0	0	0	1	D	C	B	Sets On/Off of all display (D), cursor On/Off (C) and blink of cursor position character (B).
Cursor/display shift	0	0	0	0	0	0	1	S/C	R/L	*	*	Sets cursor-move or display-shift (S/C), shift direction (R/L). DDRAM contents remains unchanged.
Function set	0	0	0	0	0	1	DL	N	F	*	*	Sets interface data length (DL), number of display line (N) and character font(F).
Set CGRAM address	0	0	0	0	1	CGRAM address					Sets the CGRAM address. CGRAM data is sent or received after this setting.	
Set DDRAM address	0	0	0	1	DDRAM address					Sets the DDRAM address. DDRAM data is sent or received after this setting.		
Read busy-flag and address counter	0	1	BF	DDRAM address					Reads Busy-flag (BF) indicating internal operation is being performed and reads address counter contents.			
Write to CGRAM or DDRAM	1	0	write data								Writes data to CGRAM or DDRAM.	
Read from CGRAM or DDRAM	1	1	read data								Reads data from CGRAM or DDRAM.	

Schwartz, Eric M. "EEL 4744: Microprocessor Applications." LCD Commands. 17 Mar. 2002.
<http://mil.ufl.edu/4744/docs/lcdmanual/commands.html>.

Bit names		
Bit	Settings	
I/D	0 = Decrement cursor position	1 = Increment cursor position
S	0 = No display shift	1 = Display shift
D	0 = Display off	1 = Display on
C	0 = Cursor off	1 = Cursor on
B	0 = Cursor blink off	1 = Cursor blink on
S/C	0 = Move cursor	1 = Shift display
R/L	0 = Shift left	1 = Shift right
DL	0 = 4-bit interface	1 = 8-bit interface
N	0 = 1/8 or 1/11 Duty (1 line)	1 = 1/16 Duty (2 lines)
F	0 = 5x7 dots	1 = 5x10 dots
BF	0 = Can accept instruction	1 = Internal operation in progress

Notes:

- DDRAM = Display Data RAM.
- CGRAM = Character Generator RAM.
- DDRAM address corresponds to cursor position.
- Address Counter is used for both DDRAM and CGRAM.
- *= Don't care.
- DL: 0 = 4-bit interface; 1 = 8-bit interface
- N: 0 = 1 line; 1 = 2 lines
- F: 0 = 5x7 dots; 1 = 5x10 dots
- For more info, see:
<http://mil.ufl.edu/4744/docs/lcdmanual/commands.html>