

EEL-5666: Intelligent Machines Design Lab

Today's Menu

- DC Motors
- Servos
- Stepper Motors
- Pulse-Width Modulation
- Solenoids

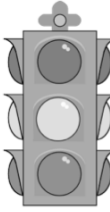

University of Florida, EEL 5666
© Drs. A. A. Arroyo & E. M. Schwartz

1

EEL-5666: Intelligent Machines Design Lab

Electric Motors

- An electric motor converts electrical into mechanical energy.
 - > Motors come in all manner of shapes and sizes.
 - There are electromagnetic direct current (DC) motors and electromagnetic alternating current (AC) motors and multiple variations of each.
 - > AC motors are typically used for large machinery (such as washers, dryers, machine tools, A/C units and the like) and are powered from an AC power source.
 - AC motors have such titles as single-phase, split-phase, capacitor start, and three-phase motors, to name a few.
 - AC motors are seldom used in our robots because a mobile robot's power supply is typically a DC battery or battery pack.
 - > DC motors appear in a large variety of shapes and sizes:
 - Permanent magnet iron core, permanent magnet ironless rotor, permanent magnet brushless, permanent magnet stepper, and hybrid stepper

University of Florida, EEL 5666
© Drs. A. A. Arroyo & E. M. Schwartz

2

EEL-5666: Intelligent Machines Design Lab

DC Motors

- For robotic purposes, a DC motor usually runs at too high a speed and too low a torque.
 - > In order to swap these characteristics, they must be geared down.
 - > Connecting the shaft of a motor to a gear-train causes the output of the shaft from the gear-train to rotate much more slowly and to deliver significantly more torque than the input shaft.
- DC motors can be purchased with the gear-train already prepackaged inside the motor housing. They are called DC gear-head motors and are normally based on permanent magnet ironless rotor motors in order to be as lightweight as possible.



University of Florida, EEL 5666
© Drs. A. A. Arroyo & E. M. Schwartz

3

EEL-5666: Intelligent Machines Design Lab

DC Motors

- DC Motor Rotation
 - > Most DC motors have two electrical terminals. Applying a voltage across these two terminals will cause the motor to spin in one direction, while a reverse polarity voltage will cause it to spin in the other direction. The amplitude of the voltage determines the motor speed.
 - Polarity \propto direction Amplitude \propto speed
 - > **Stepper motors** have six to eight terminals. Signals applied to these wires energize different coils inside the motor sequentially. The rotor is subsequently attracted to each portion and "stepped around" in a continuous fashion. The timing of these signals determines the motor speed, the phase between signals determines direction, and the number of wires determines the motor position.

University of Florida, EEL 5666
© Drs. A. A. Arroyo & E. M. Schwartz

4

EEL-5666: Intelligent Machines Design Lab

Servo Motors

- Servos
 - > Servo motors, or servos for short, are three-wire DC motors used extensively in the toy and model airplane industries, and in the steering on a radio-controlled car. This type of assembly incorporates a DC motor, a gear-train, limit stops beyond which the shaft cannot turn, a potentiometer for position feedback, and an integrated circuit for position control.
 - > Servos use **error-sensing feedback** to correct the positioning of the device



University of Florida, EEL 5666
© Dr. A. A. Arroyo & E. M. Schwartz

EEL-5666: Intelligent Machines Design Lab

Servo Motors

- Servos
 - > The three wires in a servo correspond to power, ground and a control signal input.
 - A pulse-width signal controls to what position the motor should move.
 - An electrical circuit directs the motor to rotate to the commanded position and keeps it there.
 - > Servo motors can be extremely compact and easy to control.
 - They are mass produced for the toy industry and are therefore cheaper than any other DC gearhead motors.
 - They often find their way into mobile robot grippers, arms and legs.
 - > Servos can be **"hacked"** by stripping the controller chips, potentiometers and removing the limit stops resulting in low-cost continuously revolvable DC gearhead motors suitable for small mobile robotic applications.

University of Florida, EEL 5666
© Dr. A. A. Arroyo & E. M. Schwartz

EEL-5666: Intelligent Machines Design Lab

How a DC Motor Works

- DC Motor
 - > Electromagnetic forces in DC motors result when current-carrying conductors are placed in magnetic fields.
 - According to Lorentz's law, the resulting force is perpendicular to both the direction of the current I , and the direction of the flux field, B according to the right hand rule (where the fingers curl from the direction of the current to the direction of the flux field and the thumb points to the direction of the created force).
 - > Rotary motion requires a loop of wire.
 - Because forces are created in a direction perpendicular to both I and B 's direction, current going into the loop along one side generates a force in one direction while current going into the other side of the loop generates an opposite force.
 - The force disparity acting at a distance from the center of rotation, causes a torque. The loop will then rotate until the a force disparity no longer exists.

University of Florida, EEL 5666
© Dr. A. A. Arroyo & E. M. Schwartz

EEL-5666: Intelligent Machines Design Lab

DC Motor Speed-Torque Curves

- DC Motor
 - > The speed and torque characteristics for a DC motor depend on a variety of parameters that have to do with the geometry of the motor, the materials involved, the number of windings, and the voltage at which the motor is driven.
 - > These pertinent characteristics are often illustrated in a speed-torque graph for a given applied voltage. Efficiency, current, and power output are often plotted along with speed on the vertical axis against torque on the horizontal axis.
 - > The speed-torque curve is linear with a negative slope and has a y-intercept dependent on the applied voltage.
 - > The current increases linearly with torque and is independent of applied voltage.

Legend

η = efficiency

P = power

I = current

N = speed

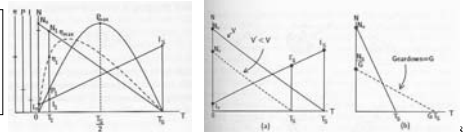

University of Florida, EEL 5666
© Dr. A. A. Arroyo & E. M. Schwartz

EEL-5666: Intelligent Machines Design Lab

Measuring Motor Torque

- A simple experiment can be performed to accurately determine the torque rating of a motor.
- All that is needed is a motor to be measured, a power supply for the motor, a piece of thread, a mass of known weight, a table, and a ruler.
 - The mass is attached to one end of the thread.
 - The other end of the thread is attached to the motor shaft so that when the motor turns the thread will be wound around the motor shaft.
 - The motor shaft must be long enough to wind the thread like a bobbin.

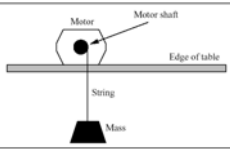

University of Florida, EEL 5666
© Dr. A. A. Arroyo & E. M. Schwartz

EEL-5666: Intelligent Machines Design Lab

Measuring Motor Torque

- The motor is put near the edge of a table with the mass hanging over the edge, as illustrated in the figure. When the motor is powered on, it will begin winding up the thread and lifting the mass. At first this will be an easy task because the moment arm required to lift the mass is small—the radius of the motor shaft.
- But soon, the thread will wind around the shaft, increasing the radius at which the force is applied to lift the mass. Eventually, the motor will stall. At this point, the radius of the thread bobbin should be measured. The torque rating of the motor is this radius per amount of mass that was caused the stall.

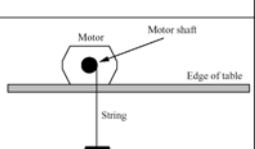

University of Florida, EEL 5666
© Dr. A. A. Arroyo & E. M. Schwartz

EEL-5666: Intelligent Machines Design Lab

Controlling Servo Motors

- Unmodified Servos
 - The integrated circuit and pot inside a servo are used to implement a closed-loop position control system. The input control signal to a servo is known as a pulse-code modulated (PCM) signal. The figure illustrates the protocol for moving the servo to a given position.
 - The servo expects a train of pulses of varying widths. The pulses are repeated at a given period, typically set at **20 ms (50Hz)**. The width of the pulse is the code that signifies to what position the shaft should turn. The center position is usually attained with 1.3-1.5 ms wide pulses, while pulse widths varying from 0.7-1 ms will command positions all the way to the right, and pulse widths of 1.7-2.0 ms all the way to the left.

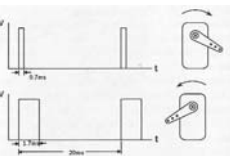

University of Florida, EEL 5666
© Dr. A. A. Arroyo & E. M. Schwartz

EEL-5666: Intelligent Machines Design Lab

Controlling DC Motors

- Controlling Motor Direction
 - A microcontroller cannot drive a motor directly because it cannot supply enough current. Instead, there must be some interface circuitry so that motor power is supplied from another power source and only the control signals derive from the microcontroller. This interface circuitry can be implemented with many technologies, such as relays, bipolar transistors, power MOSFETS (metal oxide semiconductor field effect transistors), and motor-driver ICs.
 - In all cases, the basic topology of the circuit is the so-called H-Bridge, four switches connected spatially like an H, where the motor terminals form the crossbar of the H. Each switch is implemented by a relay or transistors.

- If switches S_1 and S_4 are closed while switches S_2 and S_3 are open, the current will flow from left to right in the motor.
- When switches S_2 and S_3 are closed and switches S_1 and S_4 are open, the current will flow from right to left, reversing the motor.
- If the terminals float, the motor will free spin
- If shorted, the motor will brake.

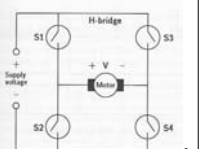

University of Florida, EEL 5666
© Dr. A. A. Arroyo & E. M. Schwartz

EEL-5666: Intelligent Machines Design Lab

Controlling DC Motors

- Semiconductor Devices - Diodes
 - > A device consisting of N-type material (silicon + an impurity such as Phosphorus which makes it more conductive) "joined" with P-type material (silicon + another impurity such as Boron which also makes it more conductive). This is called a PN junction.
 - > Diodes have two leads, called the anode and cathode. When the anode is connected to positive voltage with respect to the cathode (forward biased), current can flow through the diode. If polarity is reversed (reverse biased), no current flows through.
 - > A diode package usually provides a marking that is closer to one lead than the other (a band around a cylindrical package, for example). This marked lead is always the cathode.

The diagrams show a diode symbol with 'Cathode' and 'Anode' labels. Below it are three PN junction diagrams: (a) shows holes and electrons in P and N regions; (b) 'Forward Bias' shows current I_D flowing from P to N; (c) 'Reverse Bias' shows current $I_D = 0$ and an arrow pointing from N to P.

University of Florida, EEL 5666
© Dr. A. A. Arroyo & E. M. Schwartz

EEL-5666: Intelligent Machines Design Lab

Diodes

- Diodes

A photograph showing several diodes of different sizes and packages (axial lead, surface mount) next to a ruler marked in centimeters (2-8 cm).

University of Florida, EEL 5666
© Dr. A. A. Arroyo & E. M. Schwartz

EEL-5666: Intelligent Machines Design Lab

Light-Emitting Diodes

- LEDs
 - > LED is an acronym for "light emitting diode," so it should not come as a surprise that LEDs are diodes too. An LED's cathode is marked either by a small flat edge along the circumference of the diode casing, or the shorter of two leads.

The diagrams show a row of LEDs, a 'Bottom View' of a circular LED with a 'Flattened rim' on the cathode (-) and a larger circle for the anode (+), and a 'Side View' showing the 'Short lead' for the cathode (-) and the longer lead for the anode (+). Below are the electrical symbols for an LED.

University of Florida, EEL 5666
© Dr. A. A. Arroyo & E. M. Schwartz

EEL-5666: Intelligent Machines Design Lab

Controlling DC Motors

- Semiconductor Devices - Transistors
 - > A (bipolar) transistor is two PN junctions, back to back. There are two possible combinations of two PN junctions, *npn* or *pnp*. However, the realization and implementation of this technology has changed the world, for the third terminal on this 'dual-charge-carrier' device allows the current to be controlled. Another way to think of a transistor is as a 'current controlled switch.' The current can either be amplified when used in an analog fashion or switched when used in a digital manner.
 - > The terminals of a transistor are labeled *base*, *emitter* and *collector*. If a positive current flows into the base, the transistor conducts (a switch closes) from the collector to the emitter. If no current flows into the base, it does not conduct (a switch opens) effectively disconnecting the emitter.

The diagrams show the internal structure and electrical symbols for (a) an npn bipolar transistor and (b) a pnp bipolar transistor. Labels include C (Collector), B (Base), E (Emitter), V_{CE} , V_{BE} , I_C , I_B , and I_E .

University of Florida, EEL 5666
© Dr. A. A. Arroyo & E. M. Schwartz

EEL-5666: Intelligent Machines Design Lab
Transistor-Transistor Logic
 From EEL-3701

- TTL \equiv Transistor-Transistor Logic
- A transistor looks like a current controlled switch.
- When there is a voltage across the base-emitter ($v_{be} > 0$), there is a current i_b .
- When $i_b > 0$, the transistor conducts, and the collector to emitter junction looks like a wire (**short circuit**).
- When $i_b \approx 0$, the transistor does **not** conduct, and the collector to emitter junction looks like an **open circuit**.

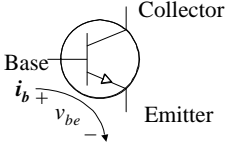

University of Florida, EEL 5666
 © Dr. A. A. Arora & E. M. Schwartz

EEL-5666: Intelligent Machines Design Lab
Controlling DC Motors

- H-Bridges
 - > By determining which pair of transistors is enabled, current can be made to flow in either of the two directions through the motor. Because permanent-magnet motors reverse their direction of turn when the current flow is reversed, this circuit allows bidirectional control of the motor.

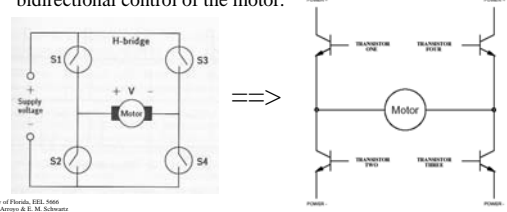

University of Florida, EEL 5666
 © Dr. A. A. Arora & E. M. Schwartz

EEL-5666: Intelligent Machines Design Lab
Controlling DC Motors

- Controlling Motor Speed
 - > To control the speed of the motor, the switches are opened and closed at different rates in order to apply a different “average voltage” across the motor. This is possible because the motor windings are inductive in nature and mechanical systems have a certain latency. The current across an inductor is given by the relation $i = (1/L) \int v dt$, where L is the inductance, i is the current and v is the voltage. The area (integral) under the voltage piecewise linear curve (by inspection) is proportional to the ratio of the amount of time the signal is high divided by the total, or the duty-cycle of the waveform. The dashed line in the figure shows the resulting average voltage applied to the motor. This technique is called *pulse width modulation* (PWM). The frequency is typically set to 20KHz, which is beyond the human hearing range.

If switches S_1 and S_4 are used for pulse width modulation while switches S_2 and S_3 are left open, the voltage across the motor will be equal to and of the same polarity as V_s when S_1 and S_4 are closed and 0 v when they are open.

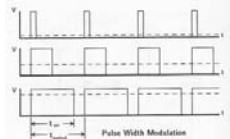

University of Florida, EEL 5666
 © Dr. A. A. Arora & E. M. Schwartz

EEL-5666: Intelligent Machines Design Lab
Controlling DC Motors

- Pulse Code Modulation vs Pulse Width Modulation
 - > Pulse code modulation for servo motors is different than pulse width modulation for controlling the speed of DC motors.
 - In PCM some “intelligence” was added so that the pulse width was a code signifying to what position the servo motor should move.
 - In PWM we use varying pulse widths to create different average voltages across to the motor to change its speed.
- Make your own or buy?
 - > It is possible to design your own solid-state H-Bridge controller, but there are also a number of low cost single chip solutions on the market.
 - For example, one can obtain several engineering samples of 1A motor driver ICs from Texas Instruments (TI) free of charge!

University of Florida, EEL 5666
 © Dr. A. A. Arora & E. M. Schwartz

EEL-5666: Intelligent Machines Design Lab

Solenoid

- For our purposes, a **Solenoid** converts energy into linear motion (e.g., a linear solenoid). (Rotary solenoids also exist.)
- Solenoid: An assembly used as a switch, consisting of a coil and a metal core free to slide along the coil axis under the influence of the magnetic field.
- Solenoids generally have two stable positions, fully
 - > Springs are often used to moved the solenoid to one of the stable positions and a current through the coil moves it to the other position.



University of Florida, EEL 5666
© Dr. A. A. Arroyo & E. M. Schwartz

21

EEL-5666: Intelligent Machines Design Lab

The End!

University of Florida, EEL 5666
© Dr. A. A. Arroyo & E. M. Schwartz

22