

Simplified LCD Explanation (from Exam 1, Fall 1998)

An X-Caliber5005 LCD (liquid crystal display) must be driven with a 68HC11. Memory-map the LCD to the two locations \$C000 and \$C080, where the first address is for **commands** and the second is for **data**. No other devices exist in the memory-mapped space from \$C000-\$CFFF. The LCD can display ASCII characters in 64 display positions (shown to the right).

0	1	2	3	4	5	6	7
8	9						
16							
24							
32	33	34	35	36	!	38	
							63

There are four possible commands for this LCD: Write, Read, Clear and Complement. These commands are encoded in the most significant 2-bits of a one-byte **command word**. The lower 6 bits of the command word specifies the appropriate LCD **display position**, 0 through 63.

Below describes how to write a “!” to position 37 (= \$25 = %10 0101).

- First send (write) the command \$A5 (%1010 0101) since a write command has %10 in bits 7 and 6). Write this byte to location \$C000 (the command register).
- Next send (write) the ASCII code for “!” (\$21) to location \$C080 (the data register).

C=C000 / D=C080	CMD		Display Position					
Command (CMD)	7	6	5	4	3	2	1	0
Clear	0	0						
Read	0	1						
Write	1	0						
Complement	1	1						

C=C000 / D=C080	CMD		Display Position					
Command (CMD)	7	6	5	4	3	2	1	0
Write example \$A5	1	0	1	0	0	1	0	1
Read example \$65	0	1	1	0	0	1	0	1

To read from position 37=\$25, for example:

- First send (write) the command \$65 (since a read command has %01 in bits 7 and 6) to location \$C000
- Next read the ASCII code at location \$C080.

The Clear and Complement commands require no data, and respectively blank or invert the colors of a particular LCD character position.

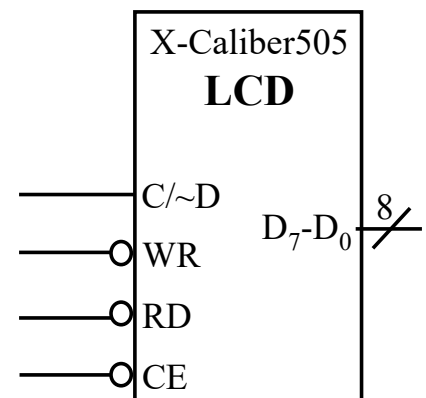

The CE, WR, and RD (sometimes called OE) operate identically to the same pins on the RAM used in lab. There is one additional control line C/~D (command/data) that tells the LCD whether the information on its data lines is a command (when high) or data (when low). On the next 2 pages, you will design a circuit (no PAL allowed) to connect the microcontroller with the X-Caliber5005 and create a subroutine to fill the LCD with characters.