

1/4	
upad_v1.4	
MCU	
Tim Martin	1.1

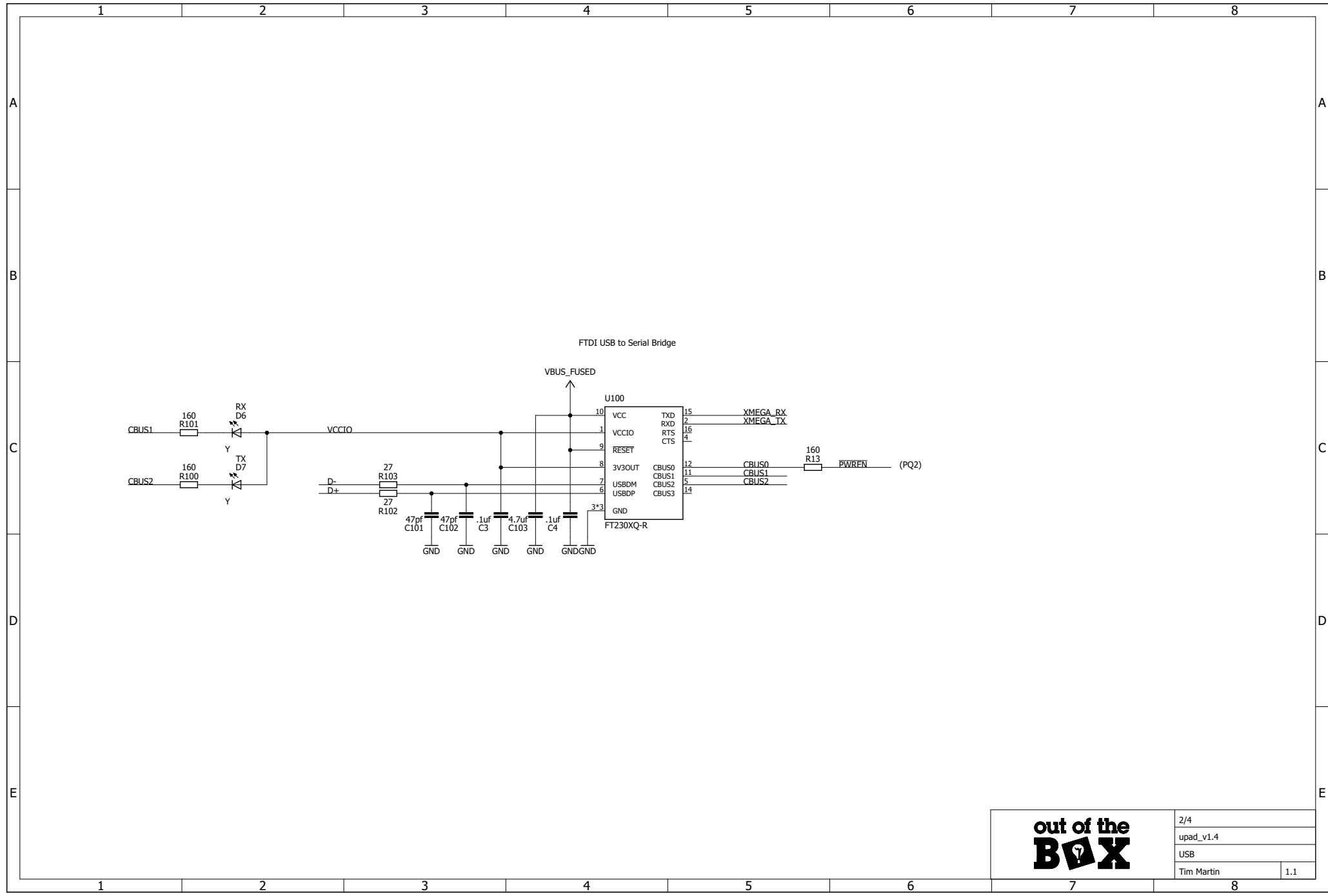

2/4	
upad_v1.4	
USB	
Tim Martin	1.1

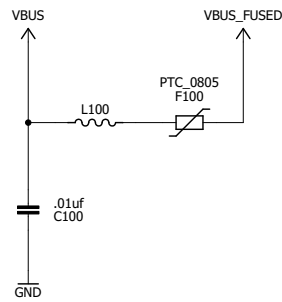

Comparator for Undervoltage Lockout

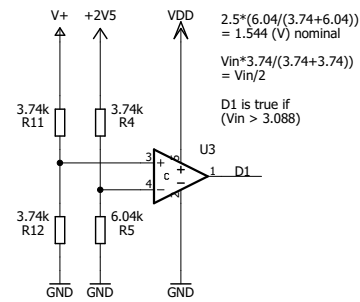

Power Supply Or Controller

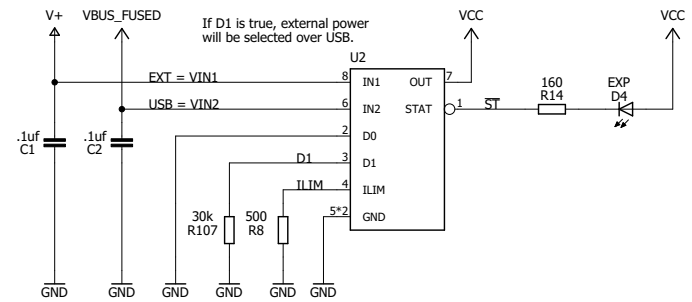

5.0V Buck Boost Regulator

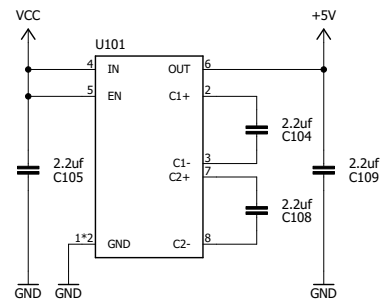

3.3V Buck Boost Regulator

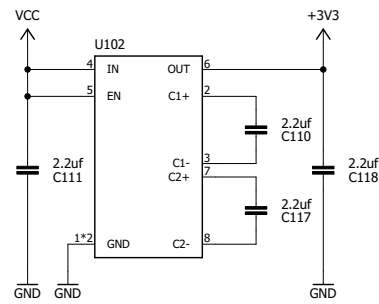

2.5V Analog Reference

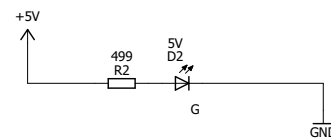
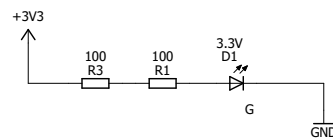
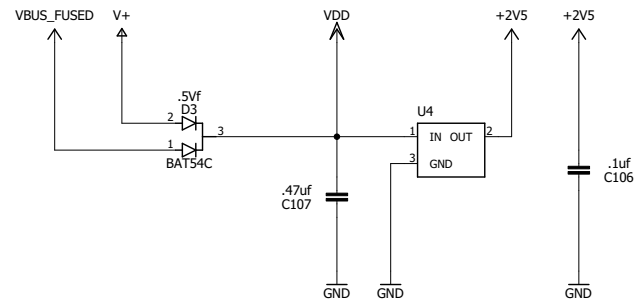

3/4	
upad_v1.4	
Power	
Tim Martin	1.1

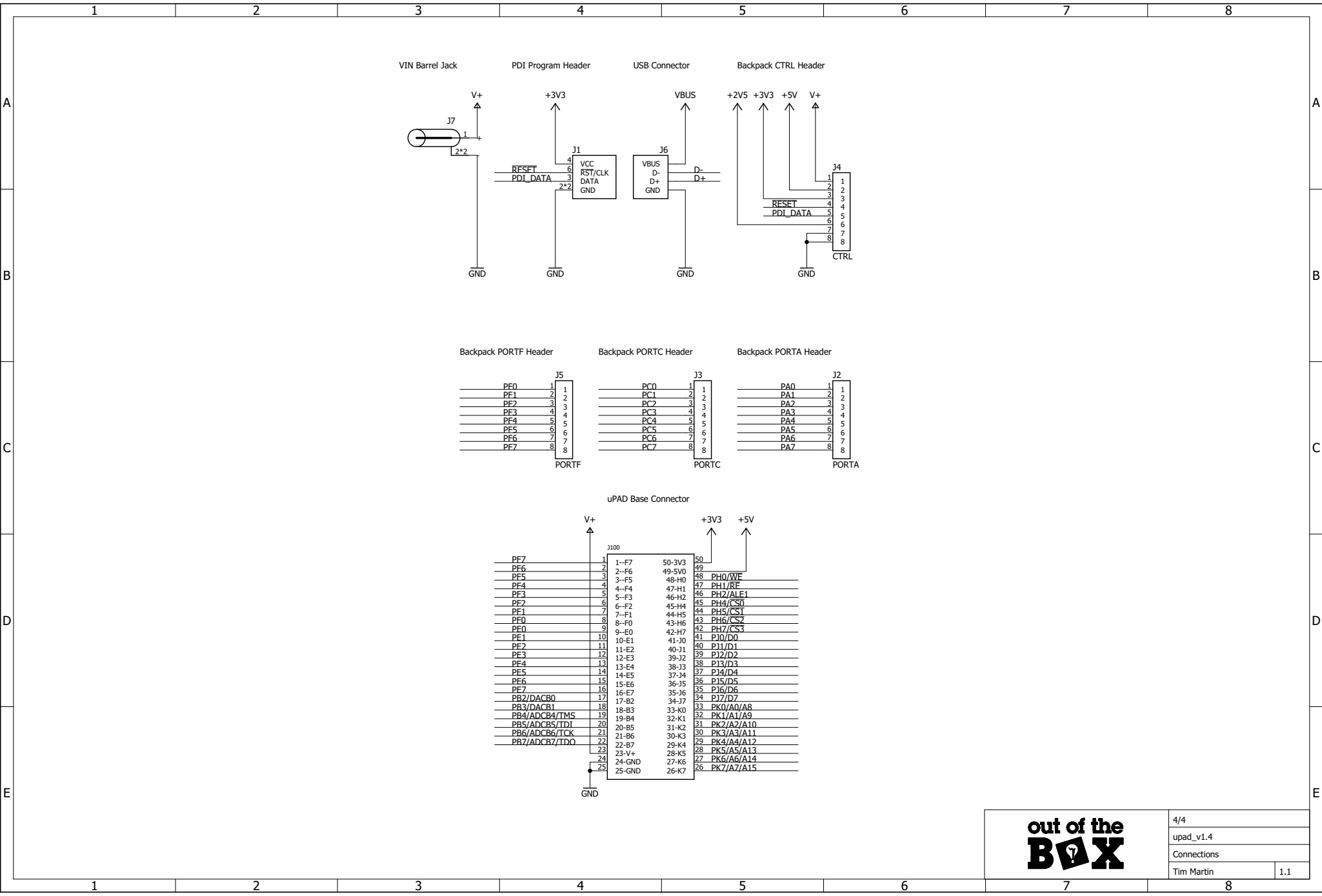

4/4	
upad_v1.4	
Connections	
Tim Martin	1.1