

Chapter 7

LEGO Design

by Fred G. Martin and Randy Sargent

LEGO Technics are fun to play with and allow the construction of great things, but they are not always easy to use. In fact, it is often quite challenging to build a LEGO device that does not fall apart at the slightest provocation.

A well-designed LEGO device should be reliable, compact, and sturdy. If it makes extensive use of gears, the geartrain should be able to rotate cleanly and easily. If it is a structural element, it should hold together squarely and resist breaking apart.

This chapter will assist the reader in his or her endeavors to create well-designed LEGO devices. It will introduce some properties of the LEGO Technic system that are not obvious at first glance.

7.1 Fundamental LEGO Lengths

Question: how long is the LEGO unit brick?

Answer: One Fundamental LEGO Unit (FLU)!

Actually, the Fundamental LEGO Unit can be expressed in other (more standard) lengths, such as the millimeter. More interestingly, the ratio between the length or width of a brick and its height is not one, but a ratio of two small integers: 6 to 5 (see Figure 7.1).

This ratio, coupled with the existence of one-third height flat pieces, allows the creation of vertical spacings that perfectly match unit horizontal ones (see Figure 7.2). By using these perfect LEGO spacings, vertical stacks of bricks can be reinforced with cross-beams, creating sturdy structures that will not fall apart.

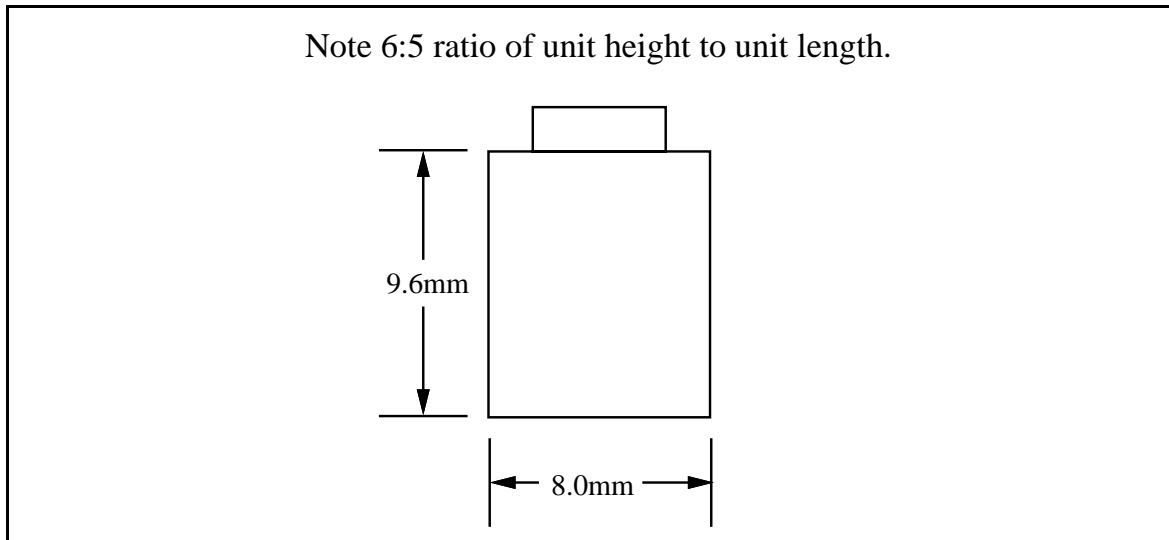

Figure 7.1: The Unit LEGO Brick

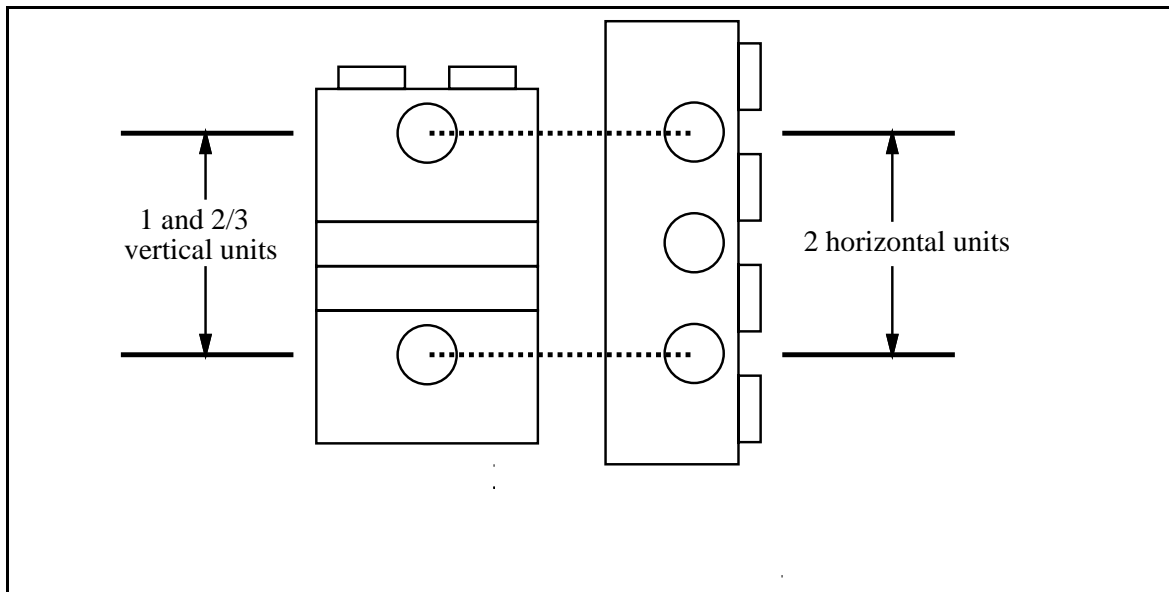

Figure 7.2: Perfect 2-Unit Vertical LEGO Spacing

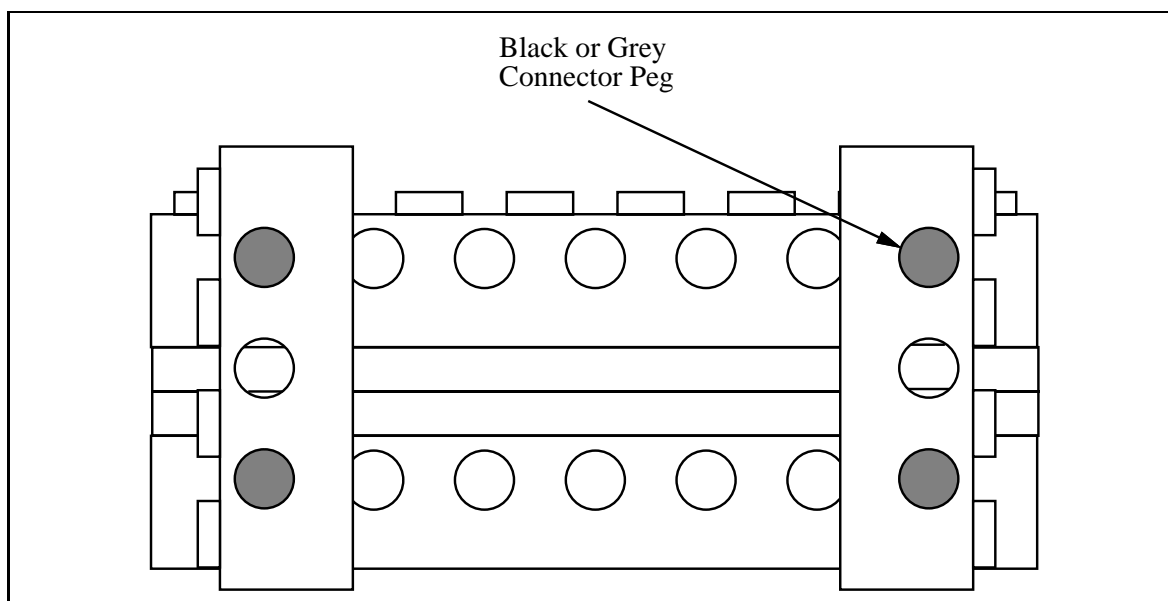

Figure 7.3: Clamping Two Beams at Perfect Vertical Spacing

Figure 7.3 shows an example of two 8-long LEGO beams (separated by a two-unit perfect spacing) braced at the ends by two 4-long LEGO beams. This structure is extremely sturdy.

Other combinations of perfect vertical spacings can be created thanks to the one-third height bricks.

A little mathematics helps us compute all of these standard combinations. Suppose a represents the number of full-height vertical units and b the number of one-third height vertical units. Then the height of a LEGO assembly (in mm) would be

$$9.6(a + \frac{1}{3}b) \tag{7.1}$$

since a full vertical unit is 9.6 mm high.



If c represents the number of horizontal units, then $8c$ is the length of a LEGO beam in mm. We then need to find integral solutions that make these two quantities equal:

$$9.6(a + \frac{1}{3}b) = 8c \tag{7.2}$$

which reduces to

$$2(3a + b) = 5c \tag{7.3}$$

The following table lists some solutions to this integer equation:

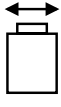
Full Height Units	One-Third Units	Horizontal Units
		
1	2	2
3	1	4
5	0	6
6	2	8
8	1	10

Bracing LEGO structures using the perfect vertical spacings is a key method of creating a structurally sturdy machine.

7.2 LEGO Gearing

Making a good LEGO geartrain is indeed a fine art. However, this art can be learned, and having some simple information can make a big difference.

One of the first things to notice about LEGO gears is their diameter, which indicates at what spacings they can be meshed together.

The natural units for the sizes of LEGO gears is the horizontal LEGO spacing unit. The following table shows the radii of the various LEGO gears:

Gear Teeth (number)	Gear Radius (horizontal units)
8	0.5
16	1
24	1.5
40	2.5

Notice that three of the gears (namely, the 8-tooth, 24-tooth, and 40-tooth) have radii that, when used together in pairs, an integral spacing is formed. So, for example, the 8-tooth gear may be used with the 24-tooth or the 40-tooth, but not the 16-tooth.

Figure 7.4 shows how an 8-tooth gear would mesh with a 24-tooth gear along a LEGO beam.

The 16-tooth gears only mesh with each other according to this logic.

Gears may be meshed together at odd diagonals. However, this requires great care, as it is difficult to achieve a spacing that is close enough to the optimal spacing (which can be computed by adding the gears' radii). If the gears are too close, they will bind or operate with high frictional loss; if they are too far, they will slip.

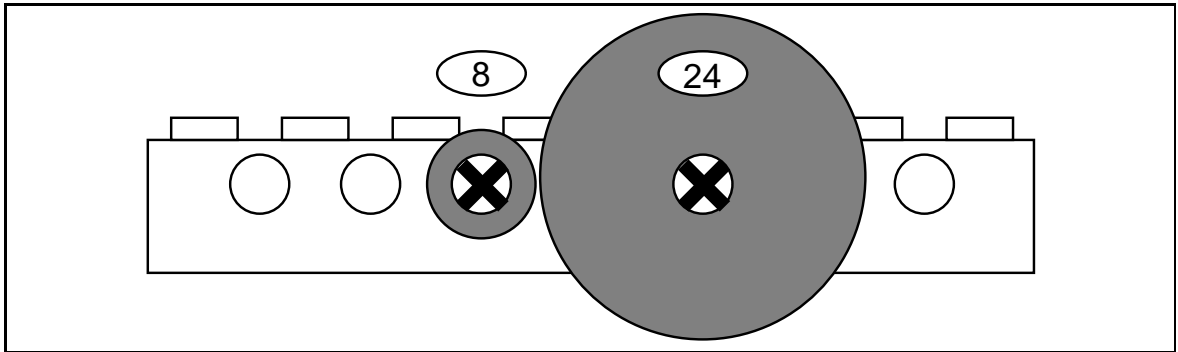

Figure 7.4: Meshing of an 8-Tooth Gear and a 24-Tooth Gear

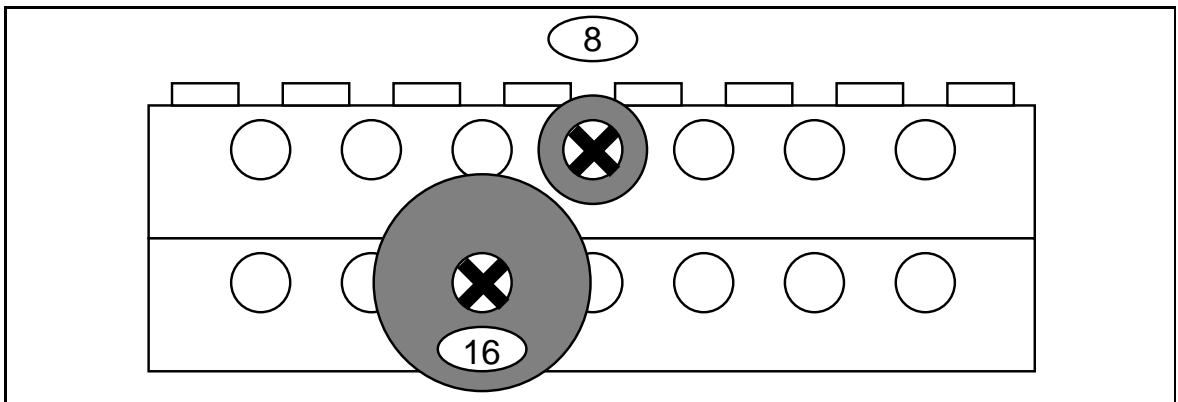

Figure 7.5: Diagonal Meshing of an 8-Tooth Gear and a 16-Tooth Gear

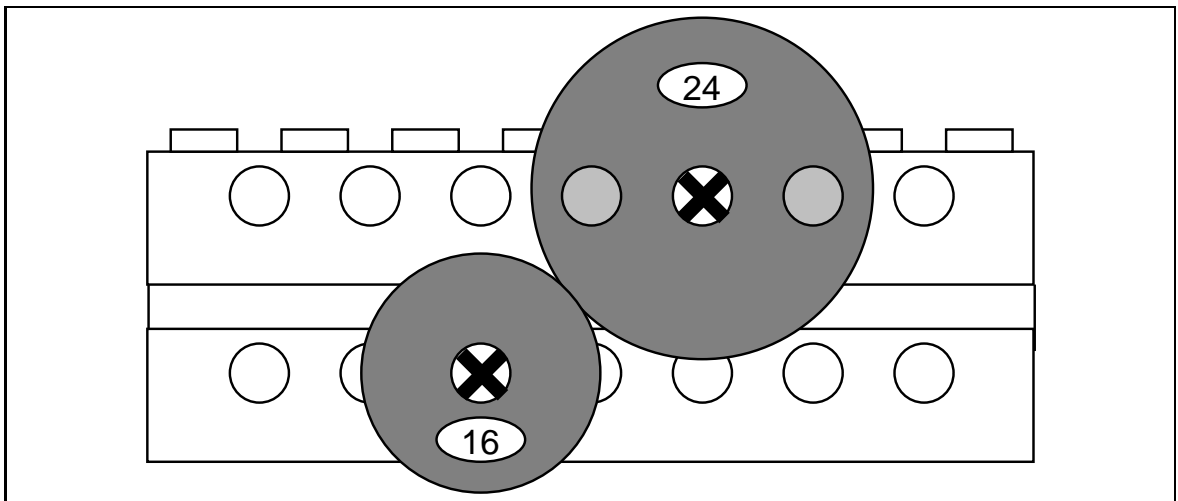

Figure 7.6: Diagonal Meshing of a 16-Tooth Gear and a 24-Tooth Gear

Figures 7.5 and 7.6 show examples of diagonal gearing that have been tested to work well. Other combinations that have good performance may be discovered.

A very high performance geartrain will be necessary in order to drive a robot. For this type of geartrain, the following rules are suggested:

- Do not use the 14-tooth bevel gear (too flimsy), the worm gear (high friction), or the right-angle 24-tooth crown gear (slips under high stresses).
- Do not make a pulley drive using the LEGO rubber bands. They are inefficient (especially in the later stages of a geartrain), they slip, and the rubber bands break or fall off at very inopportune times.
- Do use the 8-tooth and 24-tooth gears. The 40-tooth gears are also good, if they can be fit in despite their large size.
- Try to space the axles at perfect LEGO spacing, or a close diagonal approximation. This is easy to do if the axles are mounted horizontally adjacent on a beam, or vertically using perfect LEGO spacing.
- Try to have each axle supported inside at least two girders. It's also nice to space these support girders from each other. If these two rules are followed, the axles will stay straight and not bind up inside the girders and create a lot of friction.
- Where multiple girders support the same axle, make sure that these girders are firmly attached to each other. If they are not perfectly aligned, the same binding problem described above may happen, and the geartrain could lose a lot of power.
- The axles can bend. Try not to have a gear dangling at the end of an unsupported axle. Either put gears between the girders supporting the axles, or very close to the girders on the outside of the girders. Both are illustrated on the example geartrain. If the gear is two or more LEGO units away from the outside of the girders, problems may arise.
- Don't make the axles fit too tightly. After gears and spacers are put on an axle, make sure the axle can slide back and forth a little bit. It is very easy to lose a lot of power if spacers or gears are pressing up against the girders.

7.2.1 Gear Reduction

The purpose of gearing, in addition to transmitting mechanical energy, is to transform it. For the purposes of a drivetrain, the gears will change high speed and low torque

of an electric motor and create the low speed and high torque that is required to move a robot.

It is important to experiment with different gear ratios. The gear ratio determines this important tradeoff between speed and torque.

Figure 7.7 illustrates a sample LEGO geartrain. This geartrain achieves a gear ratio of 243:1 through the use of five ganged pairs of 8-tooth to 24-tooth gear meshings (this is probably a bit overkill for a robot drive).

It is suggested that a copy of this geartrain be built for evaluation—it is an efficient design that follows many of the rules that have been given.

7.2.2 Chain Drives

Use of chain drives requires a fair bit of patience on the part of the designer. A fair bit of trial and error design is necessary to find gear spacings that will work for the chain. If the chain is too loose, it may skip under heavy load. If it is too tight, it will lose power.

Experimentation is suggested. The chains tend to work better on the larger gears.

7.2.3 Testing a Geartrain

To test a geartrain to see if it is really good, try backdriving it. Take off the motor (if it's on), place a wheel on the slow output shaft, and try to turn the wheel. It should be possible to make all the gears spin freely from this slow axle. If the geartrain is very good, the gears will continue spinning for a second or two after the output shaft is released.

7.2.4 Low-Force Geartrains

When building geartrains that will only transmit small forces, many of the design rules don't apply. Some “problems” may turn out to be advantages—it may be desirable to have a transmission which “slips” when it is stuck (so that the motors do not stall) and then a rubber band and pulley drive would be appropriate.

The rubber bands are also useful for mechanisms which need to store energy.

The 24-tooth crown gear (in addition to being perfectly useable as a normal 24-tooth gear) will function at the intended 90 degree angle, as long as it is only transmitting small forces.

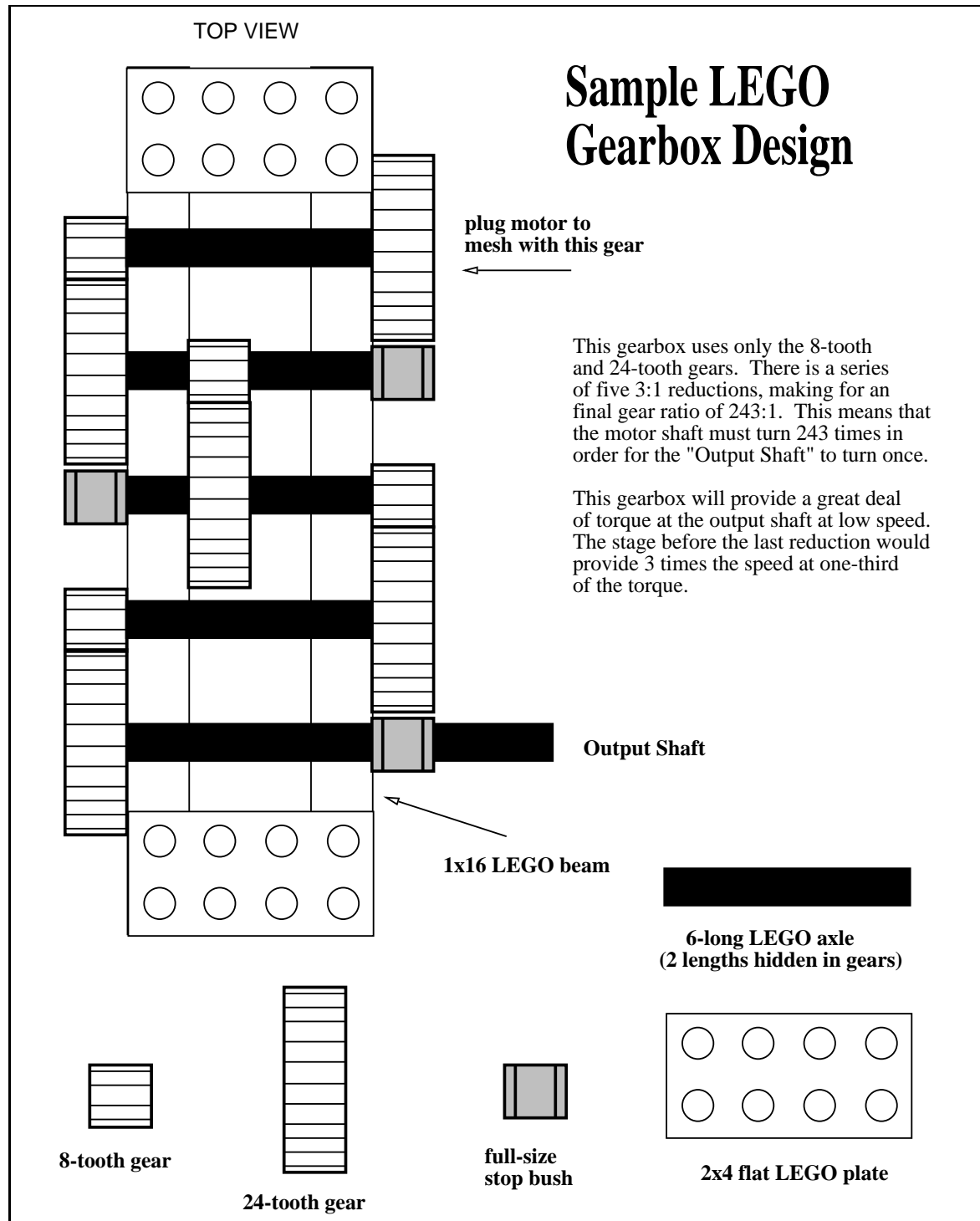

Figure 7.7: LEGO Gearbox Example